



PARTNERSHIP FOR ADVANCED COMPUTING IN EUROPE

Introduction to 3D Scientific Visualization

Training in Visualization for PRACE Summer of HPC 2013
Leon Kos, University of Ljubljana, Slovenia



Motto

- Few correctly put words is worth hundreds of images.
- To be able to place correct conclusions on complex phenomena, visualization is needed.
- At the end we want to draw simple graphs to understand behavior.
- The purpose of visualization is *insight*.

The problem

- Many experiments (real or simulation) generate huge amount of data
- Many data is multi-dimensional
- Many phenomena should not be observed isolated
- Verification by real experiment is not always possible or very expensive.

3D scientific visualization

- Why it is much more complex?
 - Size of data increase exponentially compared to 1D/2D data
 - 2D screen implies loss of some information
 - You have to select parts of interest into your data
 - “What you see is what you want to show” is not as simple
- Many different ways to render your data
 - Not compatible with all types of data
 - Some ways can be combined
 - You have to select the most adapted to your needs

Use cases

- Data exploration
- Comparative analysis
- Quantitative analysis
- Visual debugging
- Presentation graphics
- Systems control

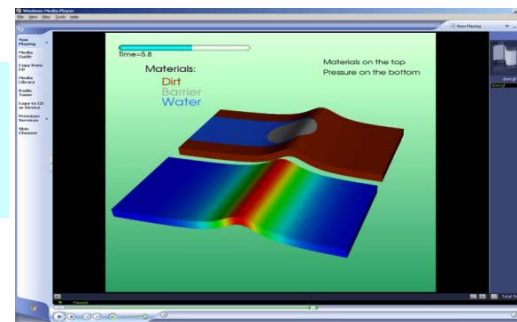
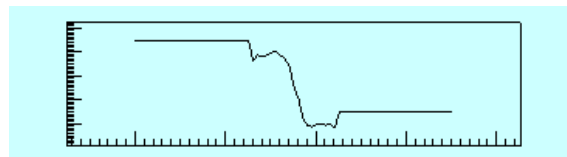
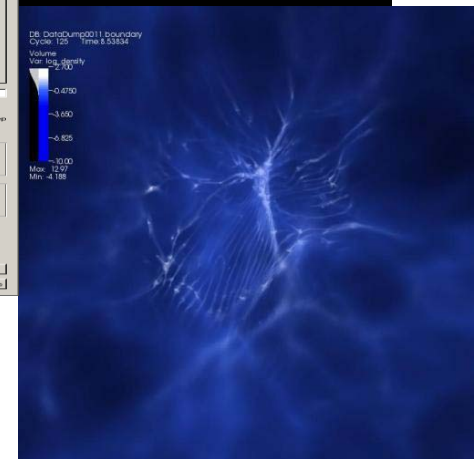
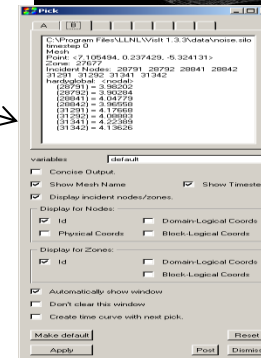
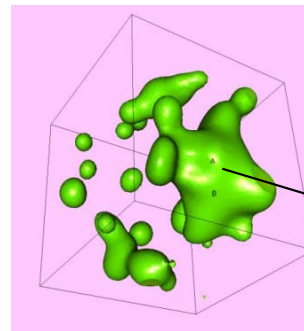
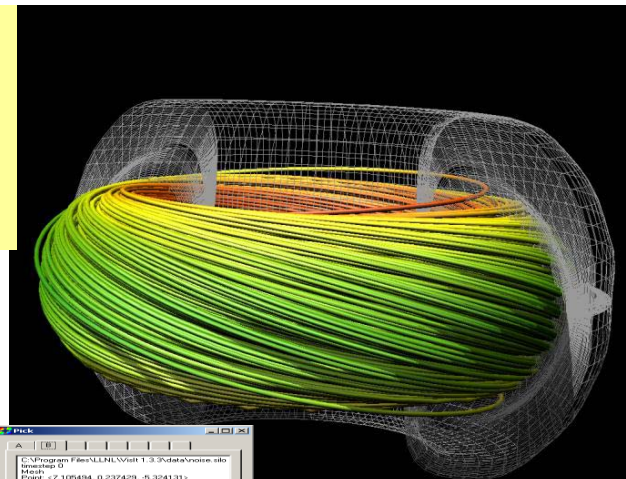
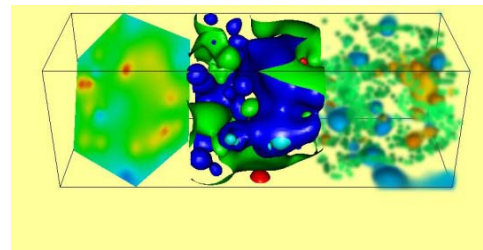

Visualization in general

- Data = geometry + structure + values
 - Uniform data – medicine
 - Regular data – CFD
 - Irregular data – mechanics, molecular structures, cosmology –
- Data dimensions
 - space
 - time-space
 - abstract dimensions

Data

Geometry

- N-dimensional point coordinates ($n=1,2,3,4$)
- Naturally given or calculated on the basis of structure or values
- Explicit or easily calculable

Structure (mesh)

- Logical relations between points
- Usually imposes possible interpolations
- Problem dependent

Values (fields)

- Scalar
- Vector
- Tensor
- Species, etc

Data and Time in a Database (or a file)

- STSD - a single time step and a single domain
- MTSD - multiple time step but only a single domain
- STMD - a single time step but multiple domains
- MTMD - multiple time steps and multiple domains

Data formats

- Brick Of Values (BOV)
- NETCDF - climate research (parallel I/O)
- HDF5 - hierarchical, self-describing array data (parallel I/O)
- SILO – LLNL favorite on top of HDF
- VTK – general purpose ASCII
- MDSplus – for experimental data
- Many “custom” formats available

Data structure (mesh and fields)

- Point, Curve

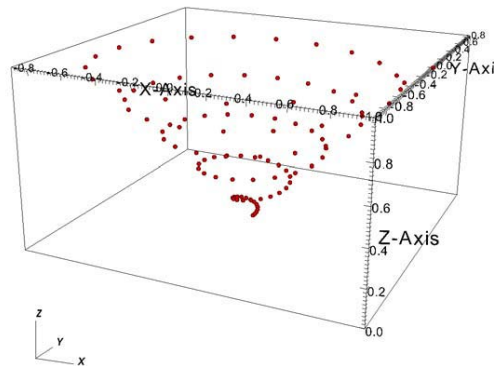
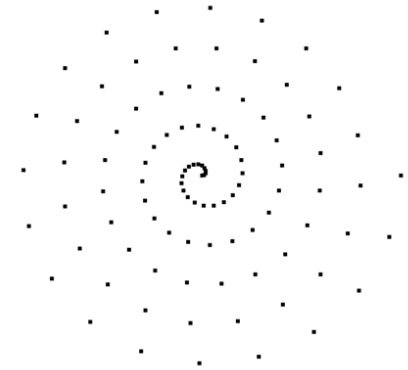

Data structure (mesh and fields)

- 2D/3D Rectilinear

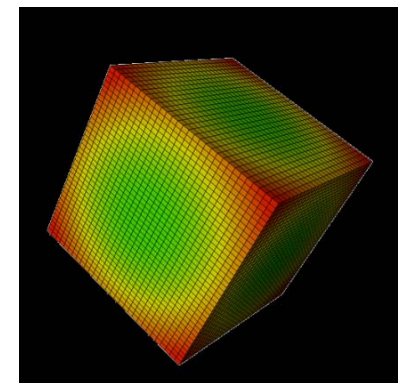
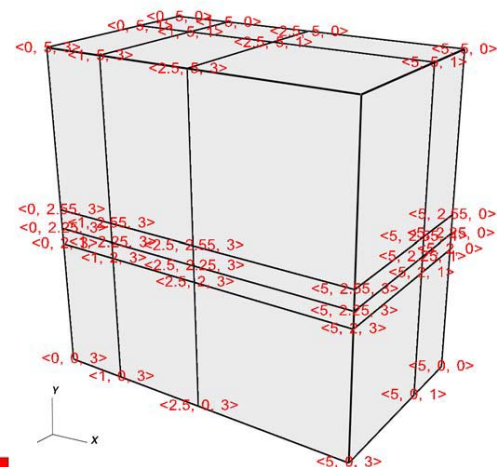
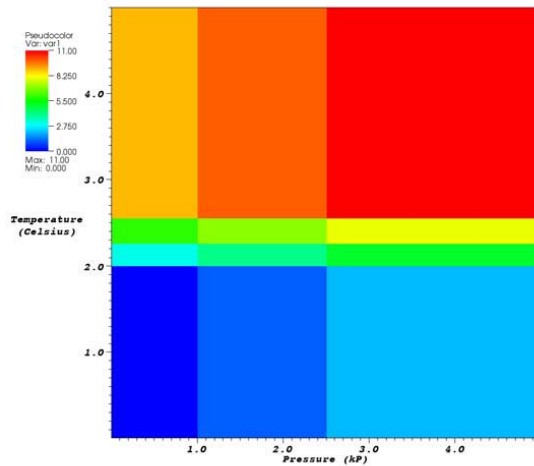
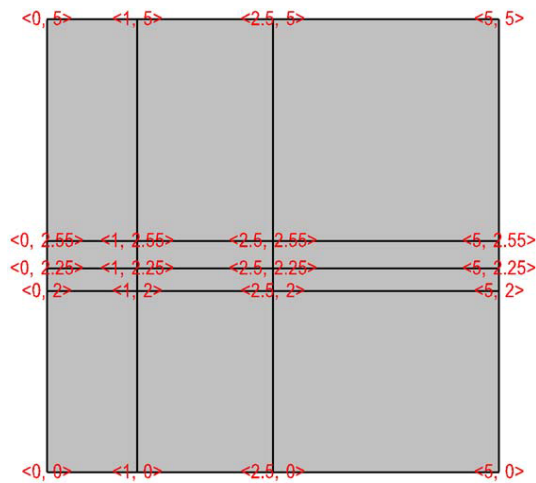

Data structure (mesh and fields)

- 2D/3D Curvilinear

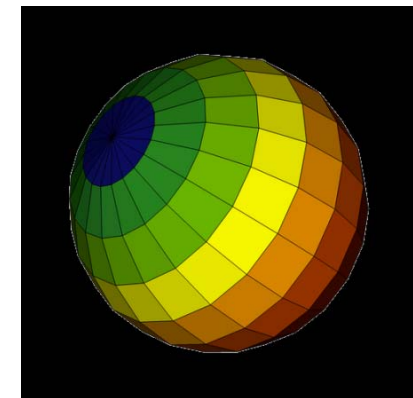
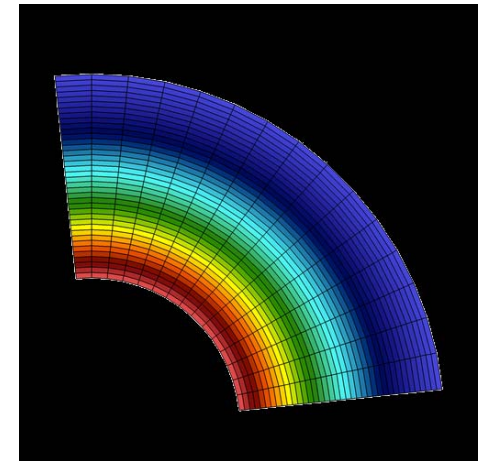
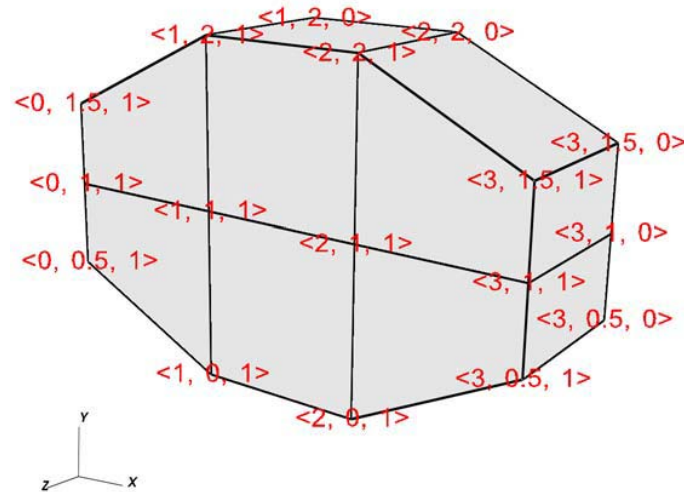
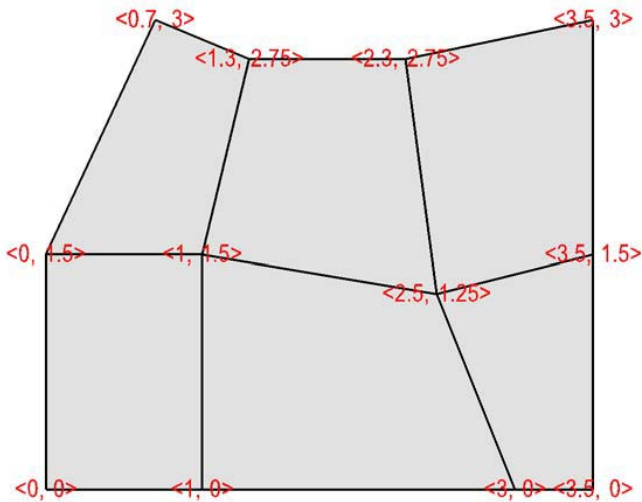

Data structure (mesh and fields)

- Unstructured

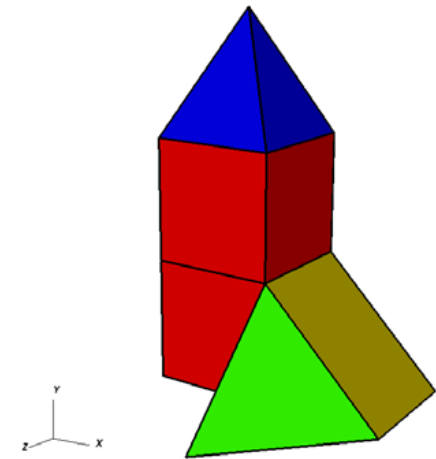
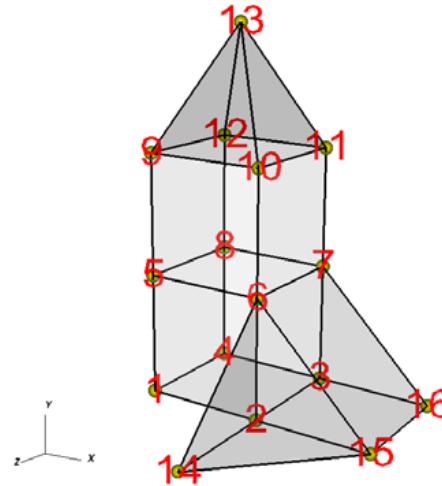
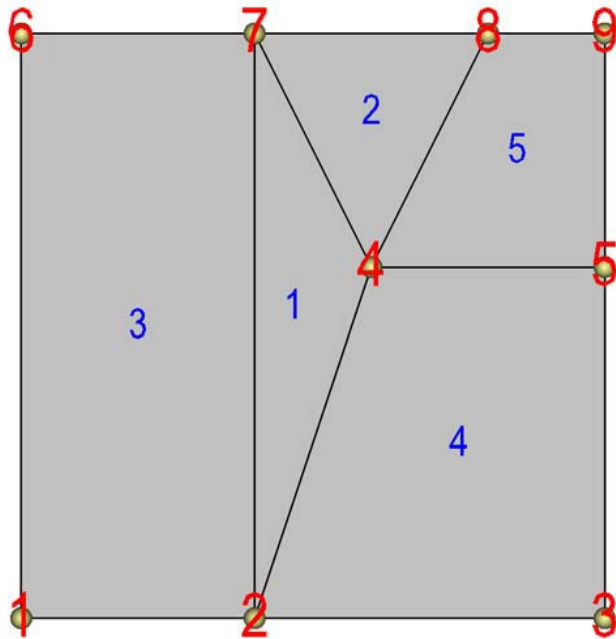

Data structure (mesh and fields)

- Adaptive Mesh Refinement (AMR)

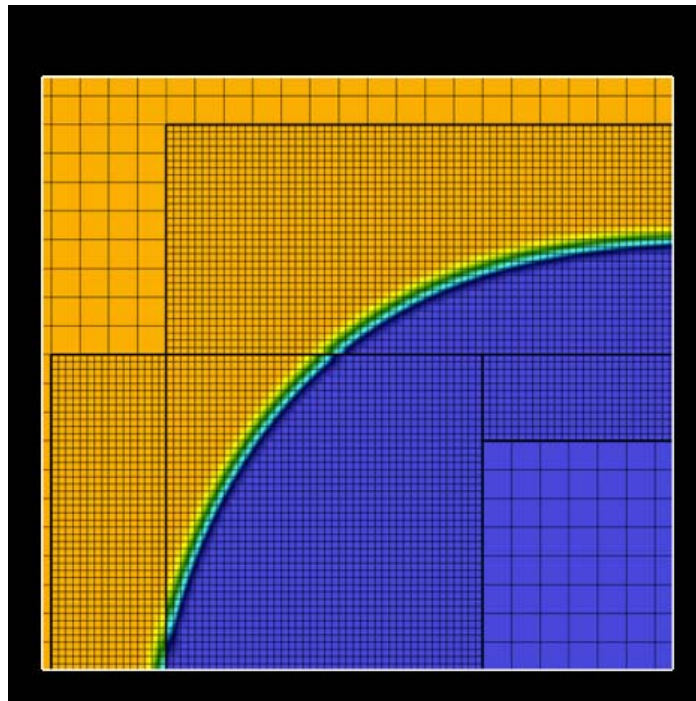

Data structure (mesh and fields)

- Domain Decomposed

Linkage by Ghost zones (G)

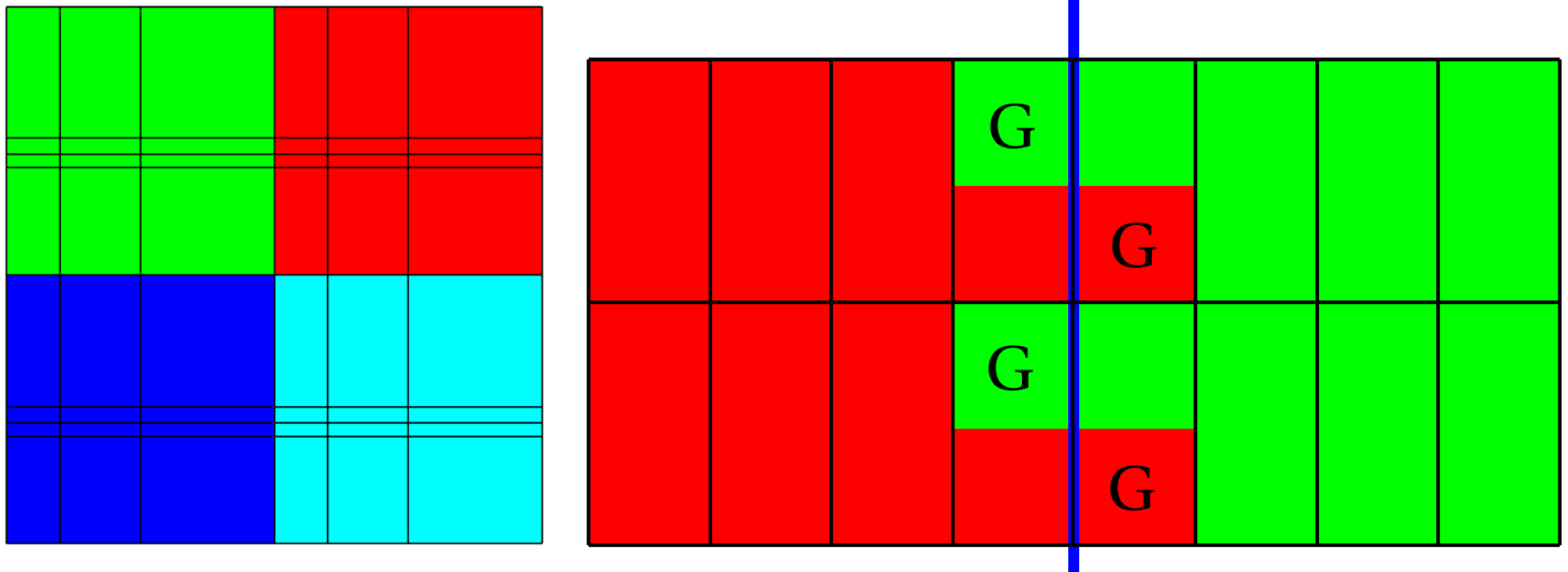

Data structure (mesh and fields)

Fields: • Scalar, Vector, Tensor, Material volume fractions, Species

Positioning:

- Zone centering
- Node centering

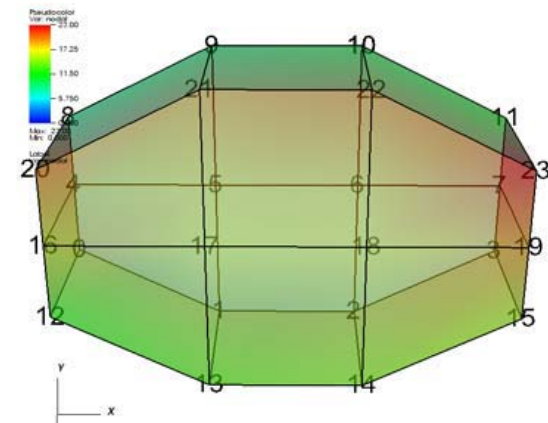
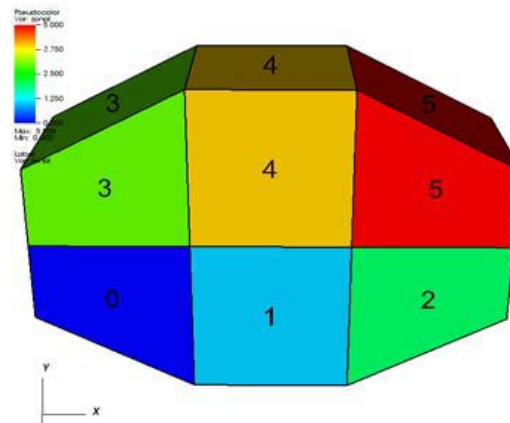
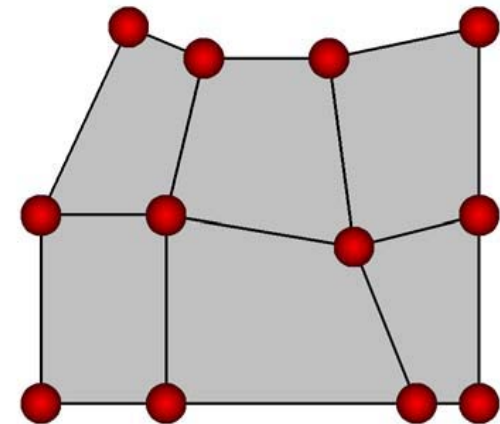
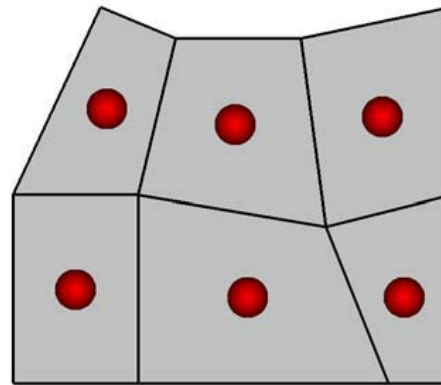

Visualization of 3D phenomena

- Ray casting (ray tracing) – result is a pixel intensity with color that includes material and light interaction. Mostly used for rendering.
- Surface rendering – triangle clouds get projected to screen coordinates. Most commonly used method.
- Volume rendering – casting rays through lattice and gathering pixel intensity. Computationally expensive
- Combination of above

3D visualization tools concepts

- Local installed tool (common and usual)
 - For small data
 - with little CPU power
 - not graphically intensive
- Visualization workstation (same as above with added values in connectivity, power and graphics performance)
- Remotely installed tool accessed by general remote desktop protocol (RDP, NX, VNC) – tool nearby data and CPU power, network protocol is a limiting factor, software rendering

3D visualization tools concepts (cont.)

- Remotely installed tool accessed by specialized network protocol (VirtualGL+VNC) – Solves network protocol limitation (to some extent) and adds remote graphics acceleration in hardware. Usually single user facility that requires advance reservation.
- Distributed client-server model - GUI and window locally. Metadata and window contents is exchanged with visualization (compute) engines. No remote graphics that must be locally powerful enough!
- Parallel client-server model (same as above with tighter CPU linkage)

Session and interactivity concepts

- Batch (send a job and receive image as result)
- No session - constantly opened transport between client and engine
- Session access provided remote desktop – disconnects/reconnects are possible
- Session store/restore – visualization configuration only
- Instrumentation – a concept of attachments to simulation
- Session attachments provided by visualization engine (non-existent to date)

Tools for 3D Scientific Visualization

- Publicly (governmental, private, consortium) driven open source tools
 - General purpose (VisIt, ParaView, MayaVi, OpenDX, Vapor, ...)
 - Specialized (AntZ, splotch, ...)
- Visualization libraries for specialized visualization
 - Visualization Tool-Kit (VTK), Imaging TK, root toolkit, ...
 - OpenInventor, OpenGL – general purpose (raw graphics only)
- Commercial tools
 - General purpose (Avizo, IDL, LabView, ...)
 - Specialized and usually part of “package”

The Visualization Toolkit

- Scientific visualization library
- Open-source, cross platform, driven by Kitware
- Most advanced features, used in public and private projects
- C++ object oriented, interfaced with Java, Python, Tcl
- Easy integration into GUI: Qt, Tk, Swing
- Stable, support parallel processing
- Open-source applications built on top of VTK
 - Paraview (Kitware), VisIt (LLNL), Mayavi (Enthought)

PARTNERSHIP
FOR ADVANCED COMPUTING
IN EUROPE



Paraview

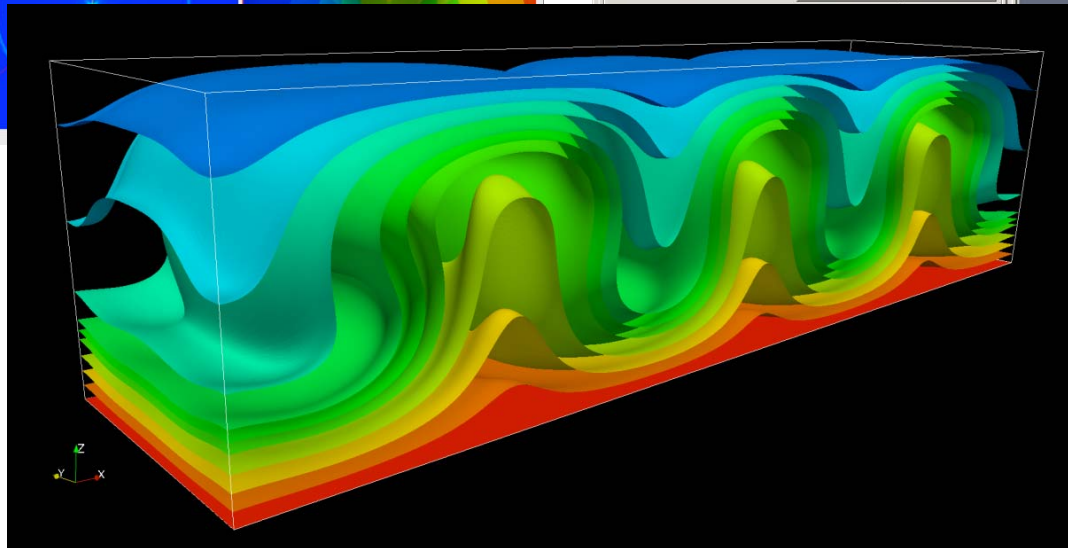
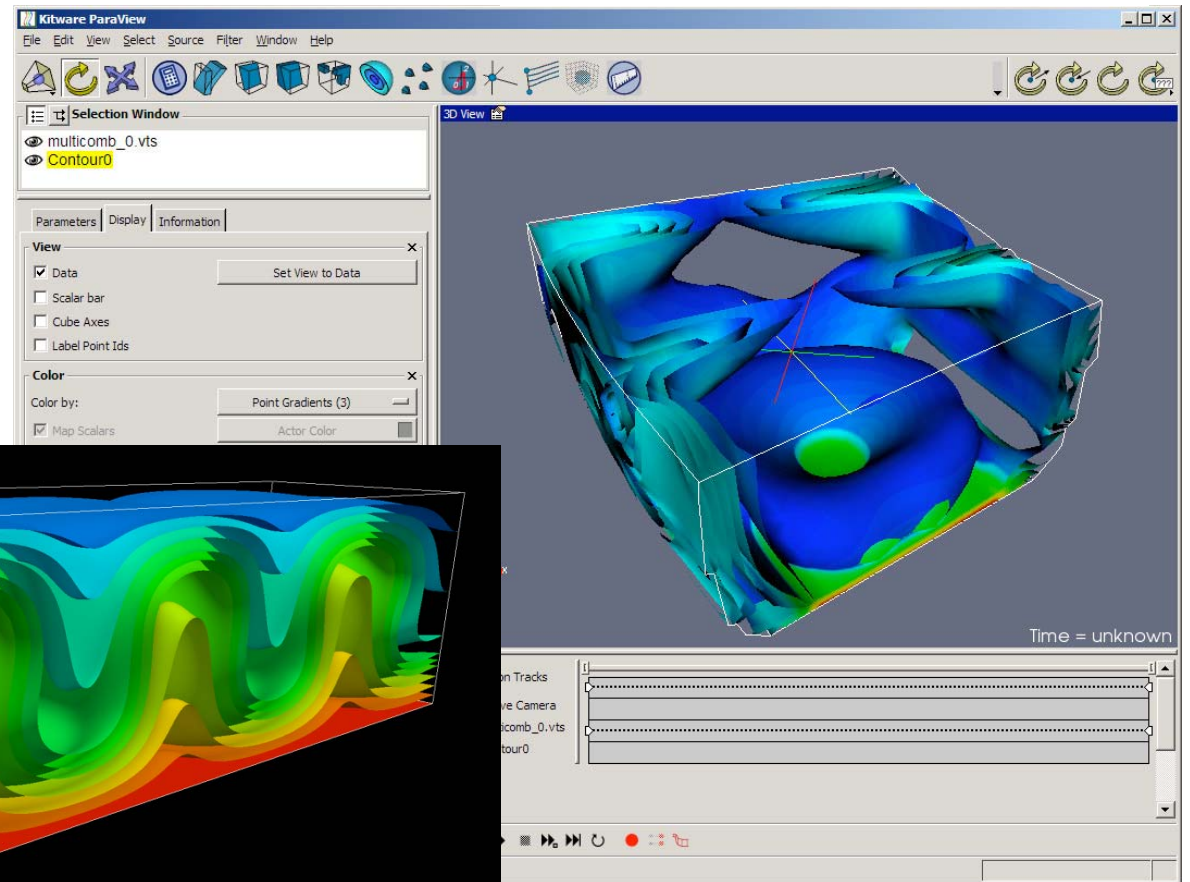
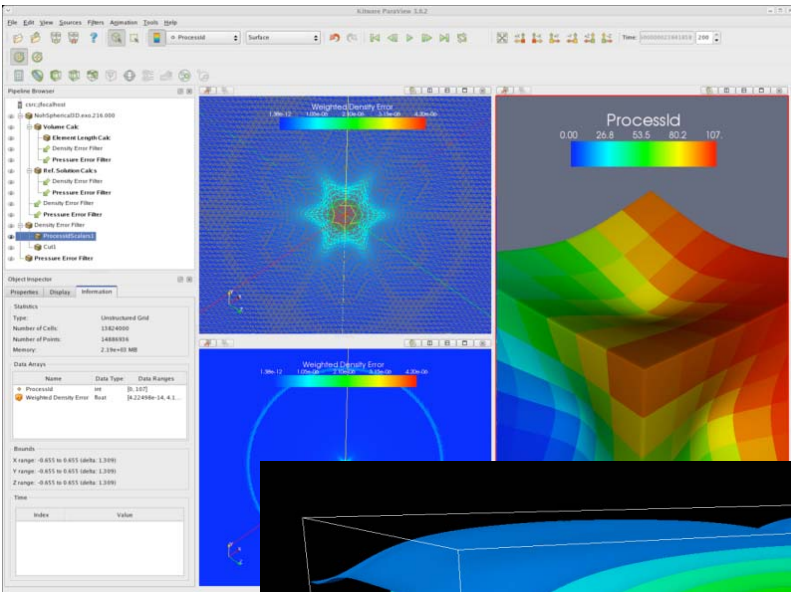

PARTNERSHIP FOR ADVANCED COMPUTING IN EUROPE



VisIt

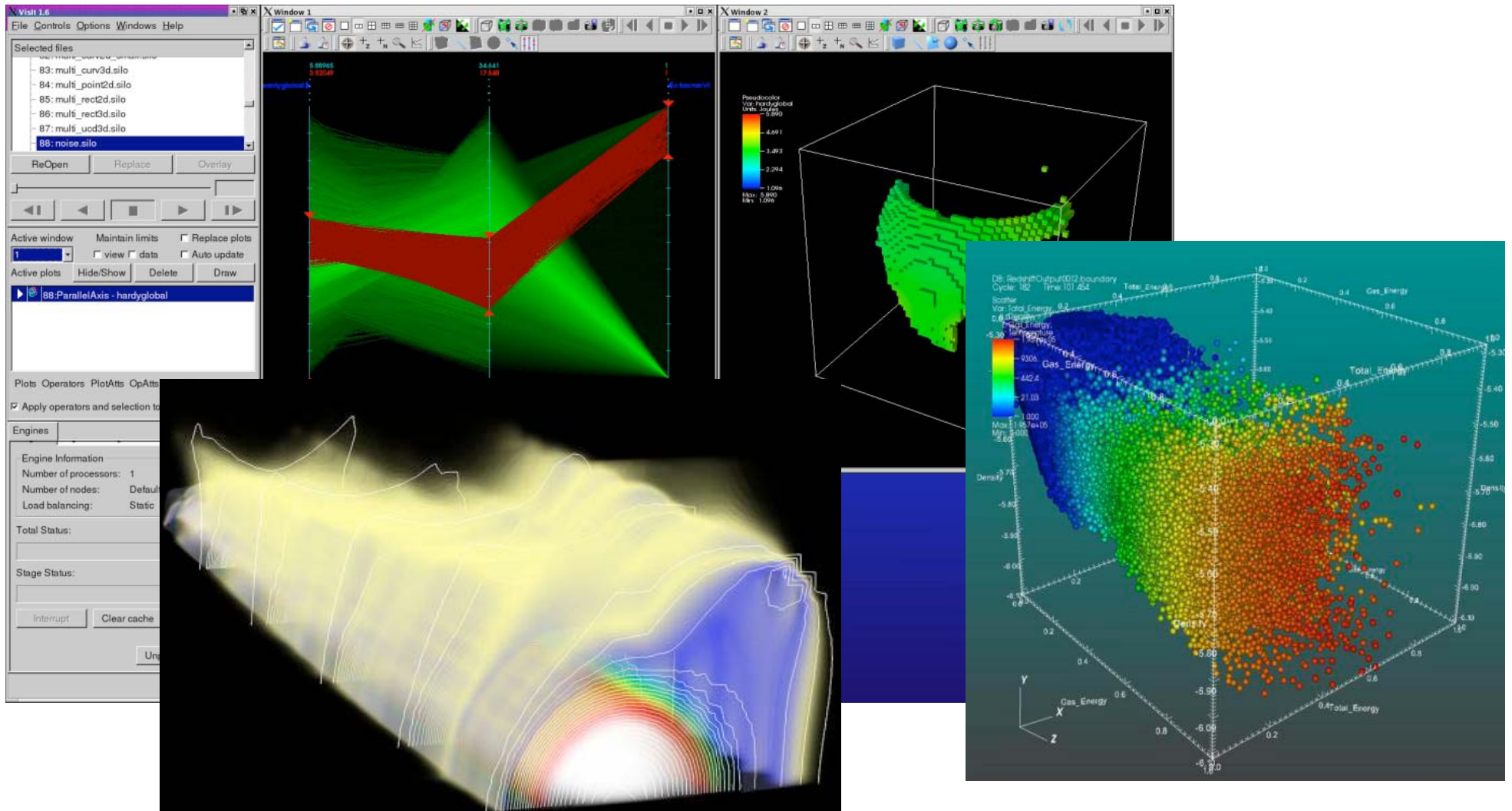

PARTNERSHIP
FOR ADVANCED COMPUTING
IN EUROPE

